

PRODUCT INFORMATION

Item number	SZ-1920
Item description	Bagged Vacuum Cleaner
The unequivocal identification of the product (type of product, trademark, trade name, model and possibly serial number)	

1.1.A



Vacuum cleaner
220-240V~ 50/60Hz 700W
Model No.: SZ-1920
Batch No.: T21303





Do not immerse in any liquid / Niet in water onderdompelen
Ne pas plonger dans l'eau / Nicht ins Wasser hineintauchen

Tristar Europe B.V. Jules Verneweg 87
5015 BH Tilburg | The Netherlands | www.tristar.eu

1.1.B

A disassembly map or exploded view

Bom list			
Serial numb	Name	Quantity	Item No.
1	handle cover	1	11.100.013S011C-H
2	handle	1	11.100.014S011C-H
3	back cover	1	11.100.01U160-H
4	on/off switch button	1	11.100.007S010C-H
5	cord reel button	1	11.100.006S010C-H
6	power cord	1	60.000.53V08-01A-H
7	spring for switch button/cord re	2	23.100.041010-H
8	axis of cord window	1	24.100.021000-H
9	cord window	1	11.100.11B000B-H
10	suction ring	1	11.100.05B000B-H
11	air outlet filter	1	40.100.CB0005-00-H
12	air outlet cover	1	11.100.12B000B-H
13	on/off switch	1	62.100.10102B-H
14	switch holder	1	13.100.01B000-H
15	dust bag	2	42.100.401180-H
16	rear seat of motor	1	30.100.06B000-H
17	dust bag holder	1	11.100.04B000B-H
18	wiring harness	1	63.100.23007-2P0-H
19	motor	1	64.100.F23007-3DL2-H
20	shake absorbing ring	1	30.100.080000-H
21	big wheel	2	12.100.02B000-H
22	base	1	12.100.13B000-H
23	rotate wheel shaft	1	11.100.16B000B-H
24	rotate wheel axis	1	24.100.011000-H
25	rotate wheel	1	11.100.17B000B-H
26	air inlet filter	1	40.100.Jw0001-00-H
27	fixting plate for rolling spring	1	24.100.031000-H
28	middle axis	1	15.100.030001-H
29	rolling spring	1	29.000.40300-H
30	left plate for cord reel	1	13.100.04B001-H
31	right plate for cord reel	1	13.100.03B000-H
32	butterfly plate	1	27.100.010000-H
33	decoration of front cover	1	11.100.003S010C-H
34	big ring	1	27.100.030000-H
35	small ring	1	27.100.040000-H
36	side plate	1	13.100.02B001-H

37	air inlet filter holder	1	12.100.03B000-H	
38	spring of dust bag holder	1	23.100.061010-H	
39	seal of dust cavity	1	33.100.03B000-H	
40	front cover lock	1	11.100.20B000B-H	
41	spring of brake wheel knob	1	23.100.051010-H	
42	brake wheel axis	1	15.100.010001-H	
43	brake wheel	1	30.100.05B000-H	
44	brake wheel knob	1	15.100.020000-H	
45	air volume tube cover	1	11.100.10J000-H	
46	air volume tube spring	1	23.100.021000-H	
47	blue indicator	1	11.100.09J000-H	
48	red indicator	1	11.100.08F000-H	
49	air volume tube	1	11.100.01J000-H	
50	front cover	1	11.100.02L160-H	

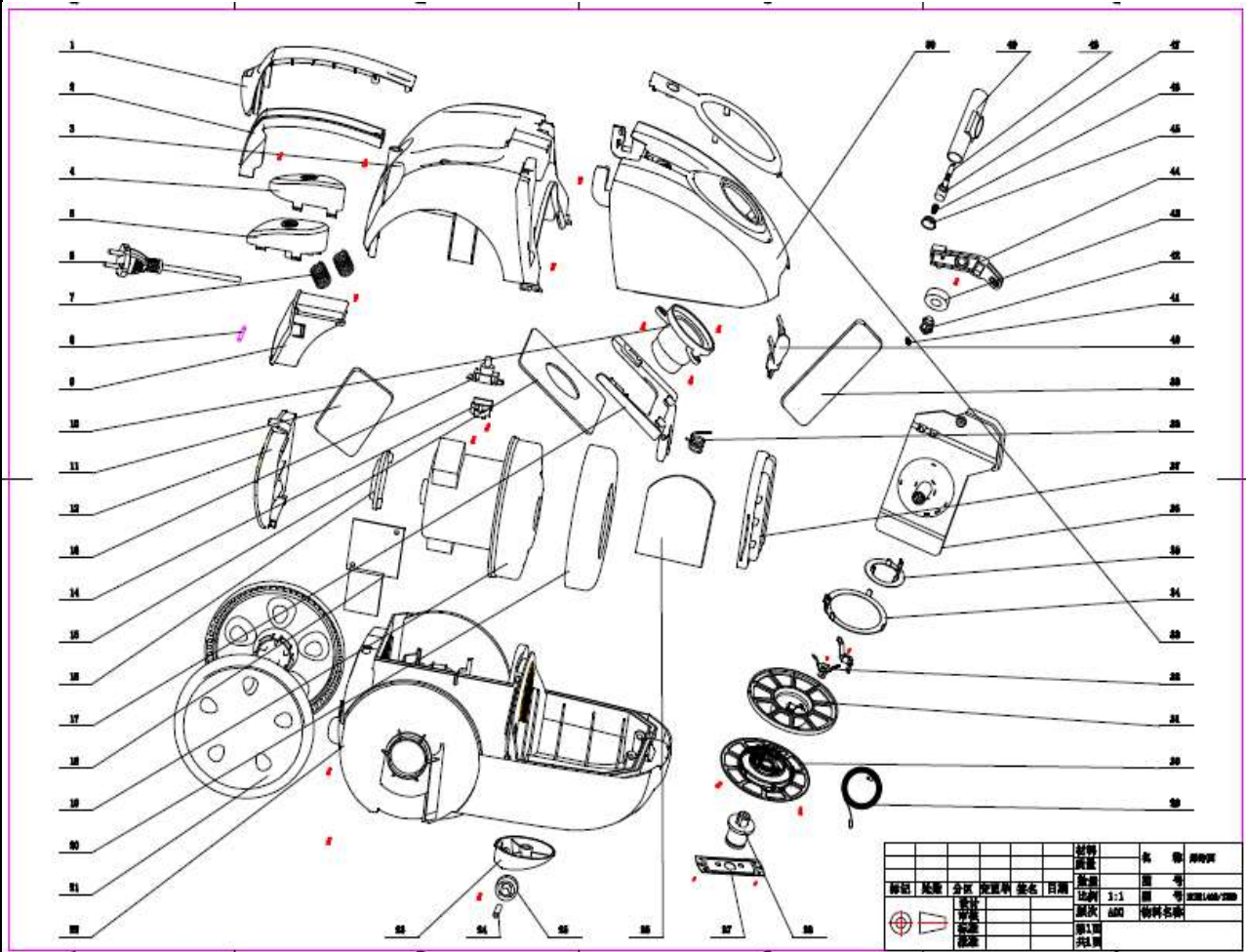

1.1.C

Wiring and connection diagrams

NOT APPLICABLE

1.1.D

Electronic boards diagrams

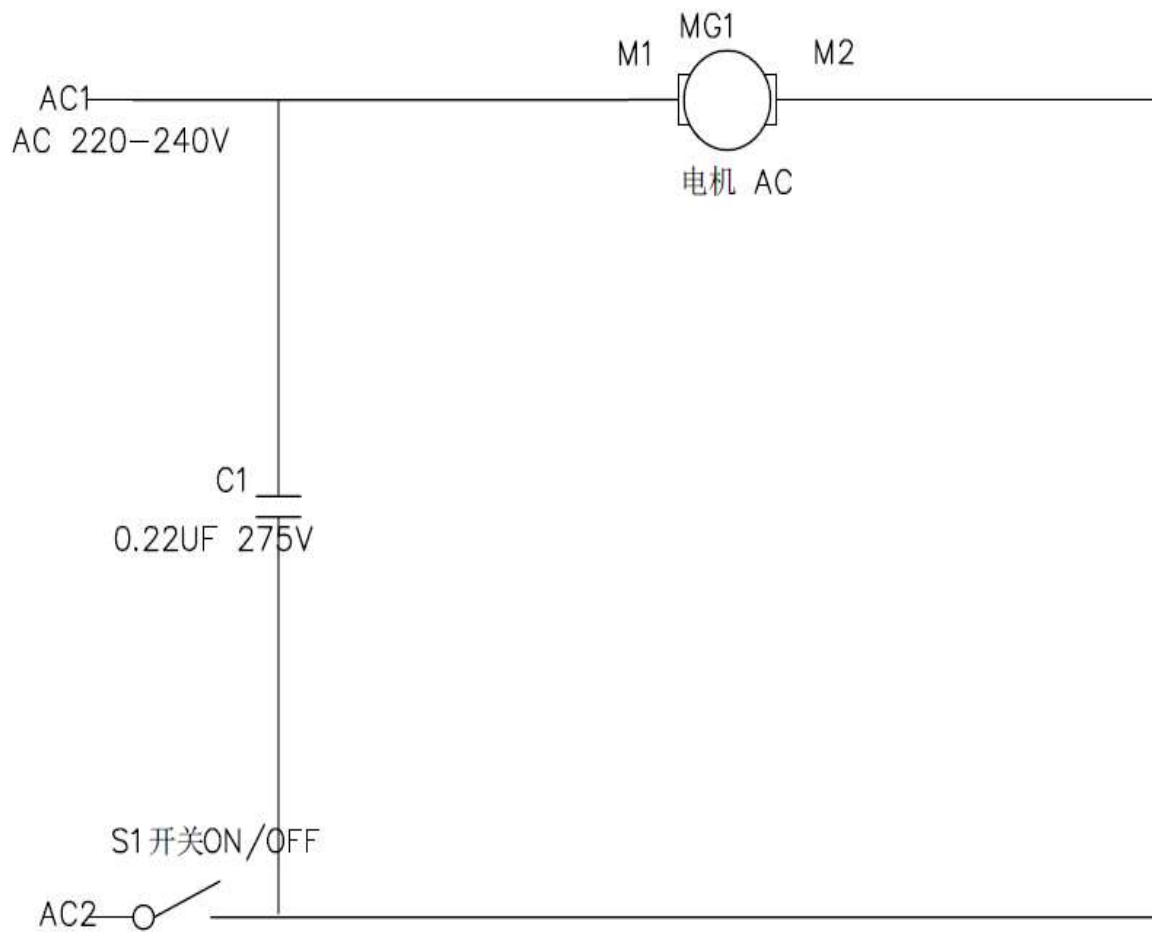

1.1.E

List of necessary repair and test equipment

SERVICE TOOLS



1.1.F

Technical manual of instructions for repair

Vacuum cleaner

Model: SZ-1920

Service Manual



Note:

Before service the unit, please read this manual first.
Contact with your service center if meet problem

Contents

1 PRECAUTION	3
1.1 Safety Precautions	
1.2 Servicing Precaution	
1.3 Cautions For Safety	
2 USER MANUAL	5
3 WIRING DIAGRAM /PCB LAYOUT	6
4 TROUBLESHOOTING	8
4.1 Machine cannot be turned on	
4.2 Low dust absorption efficiency of the machine	
4.3 Unable to retract cord automatically	
4.4 Unable to control the speed	
5 CHECK POINT OF CIRCUIT	13
6 UNPACKING WAYS OF MAIN PARTS	14
1 Remove the air inlet and outlet air filter assembly.	
2 Remove the Front Cover Assembly.	
3 Remove the Front Cover Assembly Parts.	
4 Remove the sealing ring.	
5 Remove dust bag holder.	
6 Remove the Rotate wheel.	
7 Remove the middle frame.	
8 Remove the winder assembly.	
9 Remove the motor.	
10 Remove the circuit board assembly.	
11 Remove the switch and take-up button.	
7 SERVICE TOOLS	20

1 PRECAUTION

When performing troubleshooting and part replacement during servicing, note the following safety precautions:

1.1 Safety Precautions

- Ensure that the voltage indicated on the rating label matches the mains voltage before plugging in the appliance.
- Connect the appliance to a socket that can supply a minimum of 10 amperes.
- The appliance's plug must fit into the mains socket properly. Do not alter the plug. Do not use plug adaptors.
- Do not force the power cord. Never use the power cord to lift up, carry or unplug the appliance.
- Do not touch the plug with wet hands.
- Do not use the appliance if the cable or plug is damaged.
- If any of the appliance casings breaks, immediately disconnect the appliance from the mains to prevent the possibility of an electric shock.
- Do not use the appliance if it has fallen on the floor, if there are visible signs of damage or if it has a leak.

1.2 Servicing Precautions

1.2.1 Observe Warnings

Be sure to follow special warning and precautions that are described on part labels and in the owner's manual.

1.2.2 Parts Assembly and Wiring

Be sure to use insulation material (such as tube and tape). And be sure to restore all parts and wires to their original position. Take special care to avoid contact with sharp edges.



1.2.3 Perform Safety Checks after Servicing

After servicing, check to see that the screws, parts, and wiring are restored to their original positions.



1 PRECAUTION



1.3 CAUTIONS FOR SAFETY

- Please observe the following notes for safety.
- The symbols indicate as follows.

Symbol	Meaning
 WARNING	Indicates possibility of death or serious injury of a repair technician and a person nearby through the misconducted work, or of a user by a defect of the product after the work performed by the technician.
 CAUTION	Indicates possibility of injury or physical damages* of a repair technician and a person nearby through the misconducted work, or of a user by a defect of the product after the work performed by the technician.

* Means secondary damages of property, furniture, domestic animal and pet.

Symbol	Meaning
 OUT OF CHILD	Advise the customer to keep children out of the work place. Children may be injured with a tool or a disassembled part.
 UNPLUG POWER	Unplug power cord for the work such as disassembling which is not unnecessary to power on. Do not hold the plug by a wet hand. Failing to unplug may cause an electric shock.
 USE REPAIR PARTS	Use the specified repair parts when repairing the product. Otherwise, malfunction or a defect may occur. Also, a short circuit, ignition or other danger to the customer may occur.

 INSTALL CAREFULLY	Ask an electric work shop to install the product. Install the product securely and safely according to the electrical equipment technical standard and the wiring standard. Incorrect work causes an electric shock and a fire.
 DO NOT SPLASH WATER	Do not pour or immerse electrical parts into water or liquid solution. An electric shock or ignition may occur.
 DO NOT USE WET PLACE	Do not install in a bath room or a place exposed to wind or rain. An electric shock or a short circuit may cause a fire.

2 USER MANUAL

NOTE:
Please check the user manual about the installation, operation, and spec etc.



5

2 USER MANUAL

NOTE:
Please check the user manual about the installation, operation, and spec etc.



5

3 WIRING DIAGRAM/PCB LAYOUT

3.1 During the failure diagnosing and changing components, please do it as following:

The rated voltage of the SCR in PCB is 220-240V, so it's possible to be electrical shock. Please take care while strong and weak electricity is alternative.

The design of PCB is out of failure, so prohibit to change the PCB panel according to its alarm. Please do it according to the failure diagnose program.

3.2 The circuit program

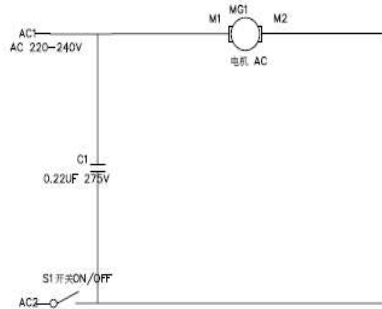

6

3 WIRING DIAGRAM/PCB LAYOUT

- 1 Motor connection cable
- 2 Main circuit board
- 3 The connecting wire of a potentiometer
- 4 Potentiometer
- 5 Switch board
- 6 Switch Connecting cables
- 7 Winder
- 8 Motor

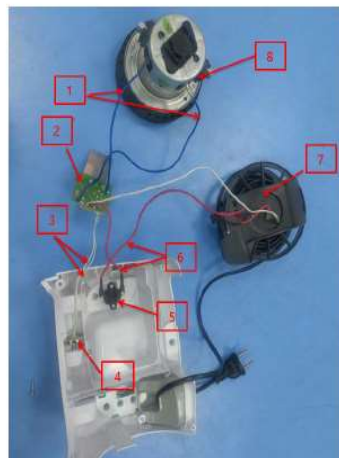

7

4 TROUBLE SHOOTING

Fault tree

1. Machine cannot be turned on

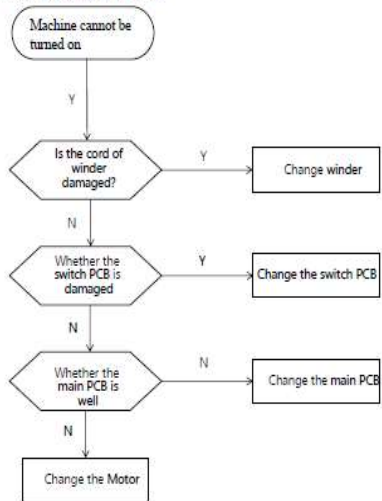

8

4 TROUBLE SHOOTING

3. Unable to retract cord automatically

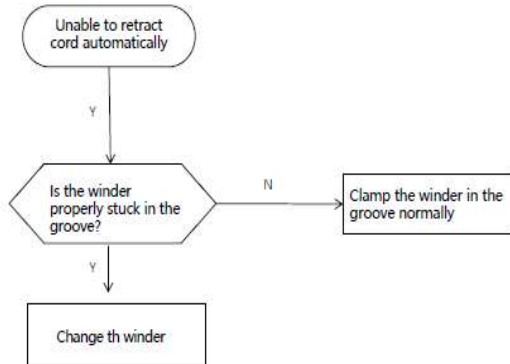

10

4 TROUBLE SHOOTING

2. Low dust absorption efficiency of the machine

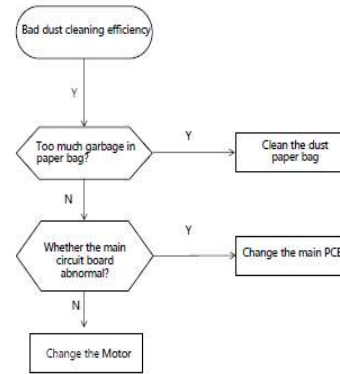

9

4 TROUBLE SHOOTING

4. Unable to control the speed

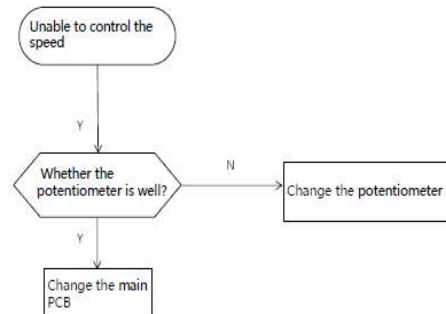

11

4 TROUBLE SHOOTING

Important:

If the suction opening of the unit, the hose or the tube is blocked, switch off the vacuum cleaner and remove the blocking substance before you start the unit again.

1. Do not operate the vacuum cleaner too close to heater or radiators.

2. Before inserting the power plug into the wall outlet, make sure that your hands are dry.

3. Before you start the unit, make sure to remove large or sharp objects that might damage the dust tank and hose.

4. When pulling out the power plug from the wall outlet, pull the plug not the power cord.

5. Do not use without all filters in place.

6. When using, if you learn of squeak from the cleaner, it must be suction appears to be reduced, so you must stop (make sure the cleaner is not plugging), then clean the all air filter.







Note:

If the supply cord is damaged, it must be replaced by manufacture, service agent or similarly qualified person in order to avoid a hazard.

12

5 CHECK POINT OF CIRCUIT

Before repairing, use multimeter to judge circuit stand of fail

No	Parts	Picture	Test Description	Parameter	Remarks
1	Motor		Use a multimeter to test whether the continuity is qualified	The motor is in the conducting state-- PASS	
2	Switch		Use a multimeter to test whether the continuity is qualified	When the switch is pressed, the switch is in the conducting state. Release the switch, the switch is off--- PASS	
3	Potentiometer		Measuring resistance	Resistance value range $470\Omega \pm 10\%$ -- PASS	

6 UNPACKING WAYS OF MAIN PARTS

UNPACKING WAYS OF MAIN PARTS

- 1 Remove the air inlet and outlet air filter assembly.
- 2 Remove the Front Cover Assembly.
- 3 Remove the Front Cover Assembly Parts.
- 4 Remove the sealing ring.
- 5 Remove dust bag holder.
- 6 Remove the Rotate wheel.
- 7 Remove the middle frame.
- 8 Remove the winder assembly.
- 9 Remove the motor.
- 10 Remove the circuit board assembly.
- 11 Remove the switch and take-up button.

6 UNPACKING WAYS OF MAIN PARTS

Operation	Picture
1 Remove the air inlet and outlet air filter assembly. Remove the dust paper bag Remove the air inlet filter grid Remove the air outlet filter grid	
2 Removing the Front Cover Assembly.	

6 UNPACKING WAYS OF MAIN PARTS

<p>3 Remove the Front Cover Assembly Parts</p> <ul style="list-style-type: none"> Remove the dust full indicator Remove the front cover locking plate Remove the Suction ring Removing the Front cover decorative block 	
--	--

6 UNPACKING WAYS OF MAIN PARTS

<p>7 Remove the middle frame</p>	
<p>8 Remove the winder assembly.</p> <ul style="list-style-type: none"> Remove Cord window 	

6 UNPACKING WAYS OF MAIN PARTS

<p>4 Remove the sealing ring</p>	
<p>5 Remove dust bag holder</p>	
<p>6 Remove the Rotata wheel</p>	

6 UNPACKING WAYS OF MAIN PARTS

<p>9 Remove the motor</p> <ul style="list-style-type: none"> Unplug the wire Remove the motor seal Remove the motor holder 	
<p>10 Remove the circuit board assembly</p> <ul style="list-style-type: none"> Remove switch assembly Remove the speed control assembly 	
<p>11 Remove the switch and take-up button</p>	

7 SERVICE TOOLS



Number	Tools	Suitable kit
1	Multimeter	Motor,
2	Soldering iron	Motor, Wire
3	Heat blower	Wire
4	Half round nose pliers	Motor, Wire
5	Screwdriver for slotted heads, cross recess	Common service tools

20

The end!

1.1.G	Diagnostic fault and error codes NOT APPLICABLE
1.1.H	Component and diagnosis information NOT APPLICABLE
1.1.I	Instructions for software and firmware (including reset software) NOT APPLICABLE
1.1.J	Information on how to access data records of reported failur incidents stored on the product NOT APPLICABLE
1.1.K	Technical bulletins NOT APPLICABLE
1.1.L	operations, safety and repair instruction, any implications for the guarantee) NOT APPLICABLE
1.1.M	How to get access to professional repairers NOT APPLICABLE
1.1.N	(consumers approach)

WARNING:
Important:

If the suction opening of the unit, the hose or the tube is blocked, switch off the vacuum cleaner and remove the blocking substance before you start the unit again.

1. Do not operate the vacuum cleaner too close to heater or radiators.
2. Before inserting the power plug into the wall outlet, make sure that your hands are dry.
3. Before you start the unit, make sure to remove large or sharp objects that might damage the dust tank and hose.
4. When pulling out the power plug from the wall outlet, pull the plug not the power cord.
5. Do not use without all filters in place.
6. When using, if you learn of squeak from the cleaner, it must be suction appears to be reduced, so you must stop (make sure the cleaner is not plugging), then clean the all air filter.

Note:

If the supply cord is damaged, it must be replaced by manufacture, service agent or similarly qualified person in order to avoid a hazard.

1.1.O

User and maintenance instructions

USE AND CARE:

- Do not use the appliance without its filter(s) correctly in place.
- Do not use the appliance if its accessories are not properly fitted.
- Do not use the appliance if the accessories or consumables attached to it are defective. Replace them immediately.
- Do not use the appliance to gather up water or any other liquid.
- Do not use the appliance if the on/off switch does not work.
- Use the appliance handle/s, to catch it or move it.
- This appliance is for household use only, not professional, industrial use.
- Store this appliance out of reach of children and/ or persons with physical, sensory or reduced mental or lack of experience and knowledge.
- Make sure that dust, dirt or other foreign objects do not block the fan grill on the appliance.
- Use the appliance and its accessories and tools in accordance with these instructions, taking into account the working conditions and the work to be performed. Use the appliance for operations different from those intended could result in a hazardous situation.
- Do not work on areas where there are metal objects, such as nails and/or screws.
- Never vacuum hot or sharp objects (cigarette butts, ashes, nails, etc.). Only use the appliance for carrying out dry tasks.

ONCE YOU HAVE FINISHED USING THE APPLIANCE:

- Turn the appliance off using the on/off button.
- Unplug the appliance from the mains.
- Retract the cable by pressing the roller cable button and guide the cable into the appliance.
- The cable housing means you can remove and have available the required length of cable for working with the appliance, preventing accident risk situations.
- Clean the appliance.